



PIT JACK

FOR ANY EVENTUALITY

MPJ – MAHA PIT JACK / PRODUCT RANGE

Load capacity	Travel	Telescopic stages	Moving range	Drive	Model
---------------	--------	-------------------	--------------	-------	-------

MPJ for cars and vans

4.0 t	750 mm	1S	H		M	MPJ 4.0/750 1S HM
			H		A	MPJ 4.0/750 1S HA

MPJ for trucks and buses

16.5 t	750 mm	1S		F		A	MPJ 16.5/750 1S FA
					T	A	MPJ 16.5/750 1S TA
			H			M	MPJ 16.5/750 1S HM
			H		A	MPJ 16.5/750 1S HA	
			H		A	E	MPJ 16.5/750 1S HAE
				F		A	MPJ 16.5/1200 2S FA
	1,200 mm	2S			T	A	MPJ 16.5/1200 2S TA
			H			A	MPJ 16.5/1200 2S HA
				F		A	MPJ 16.5/1200 3S FA
					T	A	MPJ 16.5/1200 3S TA

MPJ for heavy-duty vehicles

20.0 t	750 mm	1S		F		A	MPJ 20.0/750 1S FA
					T	A	MPJ 20.0/750 1S TA
			H			M	MPJ 20.0/750 1S HM
			H		A	MPJ 20.0/750 1S HA	

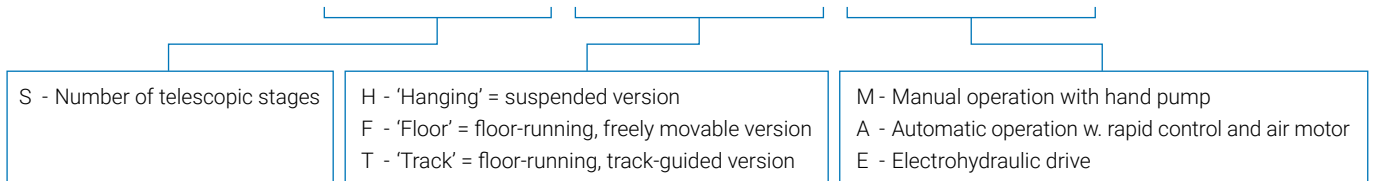

Self-explanatory naming system

Below is an exemplary breakdown for the model name of a pit jack with a load capacity of 16.5 t, a travel of 1200 mm, 3 telescopic stages, a carriage running on rails on the floor and an automatic drive (air motor and rapid control).

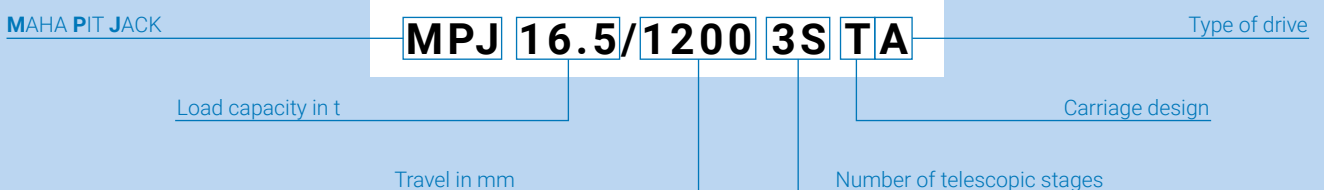

All pit jacks with "STOCK" in the product designation (VP/VZ) will be produced in stock in the future. Therefore a very short delivery time is possible.

PRODUCT PROPERTIES

Suspended pit jack

- Easy to move since centre of gravity is at the top
- Freely accessible pit floor
- No special pit floor evenness requirements
- The SAT (self-supporting traverse) is moved with the pit jack

Available options with our flexible lifting system:

- 1-stage jacks for the repair and braking segment
- 2-stage jacks for removing under-vehicle assemblies



Floor-running pit jacks (freely movable)

- Space-saving due to option of parking in pit lanes or sponson
- Can be used outside the working pit
- Support systems easy to use
- SAT very easy to move independently of the jack due to spring-loaded rollers
- Straightforward ordering process, since no dimensional drawing of the pit is required

Available options with our flexible lifting system:

- 1- and 2-stage pit jacks as above
- 3-stage jacks for removing assemblies. Mainly for use in very shallow working pits



Floor-running pit jacks (rail-guided)

- Easy to move even when loaded (vehicle gearbox)
- Different carriage rollers available as standard for different tread profiles
- No special pit floor evenness requirements
- Space-saving parking underneath the pit stairs
- Support systems easy to use
- SAT very easy to move independently of the jack due to spring-loaded rollers

Available options with our flexible lifting system:

- for 1-, 2- and 3-stage pit jacks



TELESCOPIC PIT JACK

MPJ 16.5/1200

Telescopic synchronised cylinder



Telescopes travel continuously and at the same high speed along the entire lifting and lowering path. Rapid control to the load point and back is used with synchronised cylinders in all telescopic stages. These features thus ensure completely safe, solid and jerk-free use.



Suspended

For telescopic pit jacks in difficult installation and floor conditions.



Freely movable

The rollers can rotate 360°. If the load rises above 800 kg, the carriage sets down fully automatically. For use in working pits or in conjunction with runway, multi-post or mobile column lifts.

Roller spacing designed for lift extensions according to DIN EN 1494

Easily accessible rotary handle for lowering the jack (piston rod).

Trouble-free working and ergonomic handling and movement of the pit jack due to optimised handle size.



Option: The air filter function in the maintenance unit protects the jack.



Optimum internal oil level check due to ideally placed oil sight glass

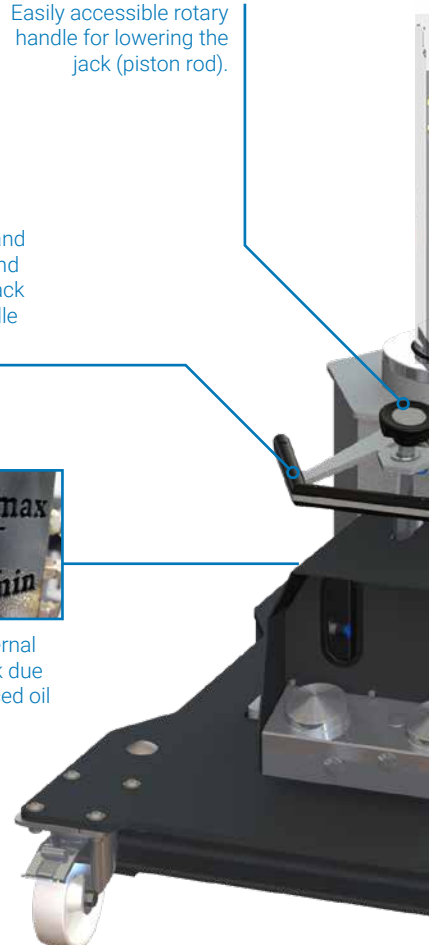

Manufacturing according to DIN EN 1494

THE 'SYNCHRONISED CYLINDER' GENERATION OF PIT JACKS GUARANTEES SAFE AND PRECISE WORKING

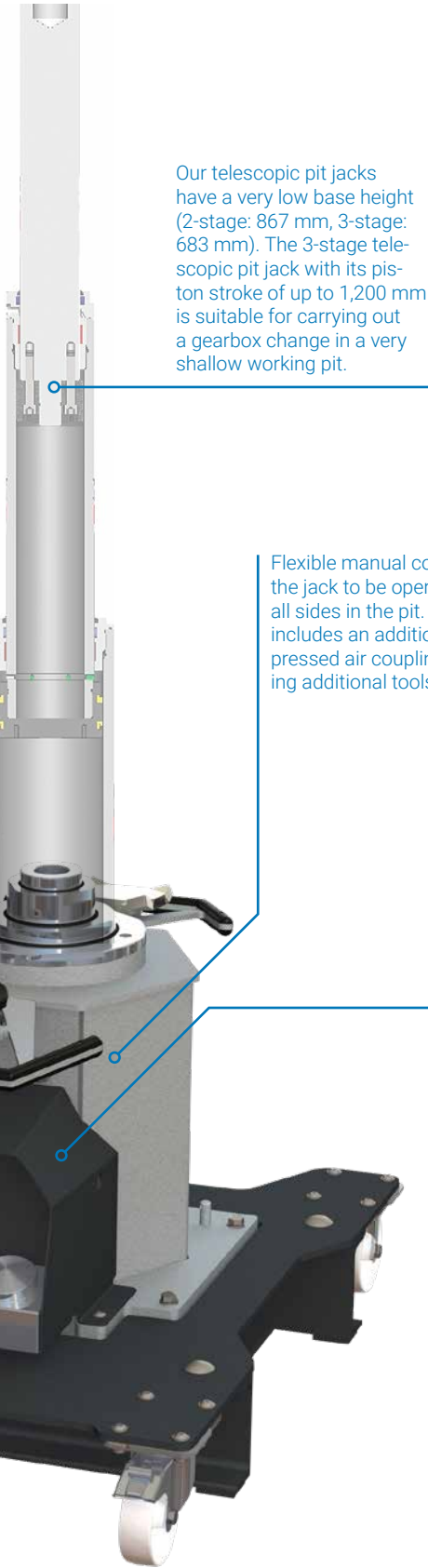

Our telescopic pit jacks have a very low base height (2-stage: 867 mm, 3-stage: 683 mm). The 3-stage telescopic pit jack with its piston stroke of up to 1,200 mm is suitable for carrying out a gearbox change in a very shallow working pit.

Flexible manual control allows the jack to be operated from all sides in the pit. This version includes an additional compressed air coupling for connecting additional tools.

The protective housing ensures that components that are susceptible to faults have a long service life.



Due to the Venturi nozzle, the jack only needs 8 bar pressure to work optimally. It also allows the use of pneumatic rapid control over all cylinder stages.

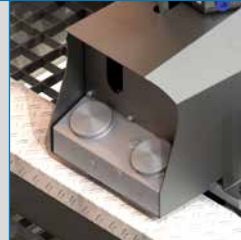

The ergonomically shaped foot pedals in the control block allow the user to comfortably rest their foot when operating the control.



Option: The foot pedal without compressed air allows precise placement of the jack on the vehicle or gearbox.

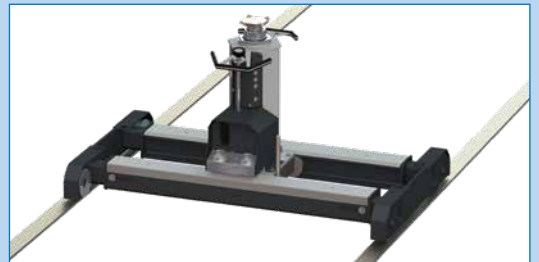

Rail-guided

For easy movement of the jack, with and without load (assembly).

Compatible rail variants:

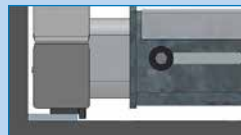

Flat steel
min. 75 x 10 mm

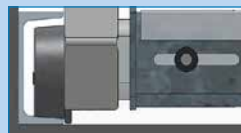

U-profile
min. U160

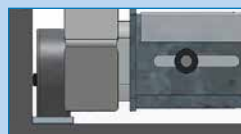

Flat steel
min. 50 x 10 mm

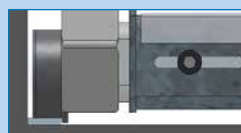

No tread on top
min. 50 mm

PIT JACK WITH 1-STAGE STROKE

MPJ 4.0/750 1S / MPJ 16.5/750 1S / MPJ 20.0/750 1S



The hydropneumatic automatic jacks combine hydraulic power with fast pneumatics. Alternatively, a manual hydraulic system can be used.



The electrohydraulic automatic jack moves up and down quickly due to the pump's constant pressure.

Our lifting systems are designed for a pit profile distance of up to 1,200 mm

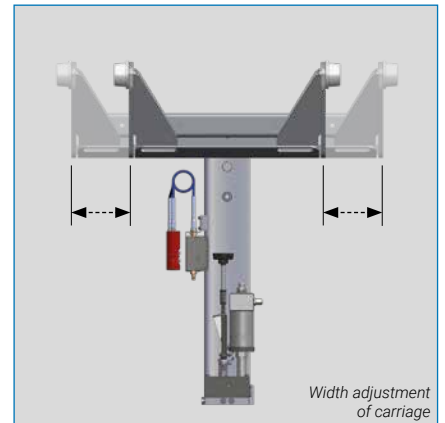

- All jack rollers are equipped with needle bearings. A jack brake can be used to secure the transverse displacement.
- The treads are covered for protection and also secure the jack against toppling off the rails.
- Shelves and handles are fitted to the jack carriage for easy working with the jack.

Our jack carriage up to 16.5 t are flexibly adjusted to the pit dimensions (580 – 1,200 mm) by moving the side plates. The adjustment range is calculated in stages, allowing the jack to be mounted in a closed pit profile.

The control is not only optimal, but flexible too



Manual control
with two pumps and lever arm extension for ergonomic operation



Automatic mode
with air motor and compressed-air rapid control.



Compressed-air manual control
for three-sided use for flexible and safe automatic operation of pit jacks. With magnetic head for storage on many jack modules.



Electric control
Two-button control for raising and lowering. The lowering cycle can be adjusted in terms of speed.

SELF-SUPPORTING AXLE TRAVERSE (SAT)

SAT 14.5

Self-supporting axle traverse with two-point support for safe vehicle lifting and set-down.

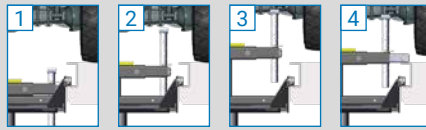

- 1 SAT mounted on the jack
- 2 SAT is applied to the vehicle
- 3 SAT lifts the vehicle freely
- 4 SAT securely supports the vehicle

Vehicle support by means of SAT

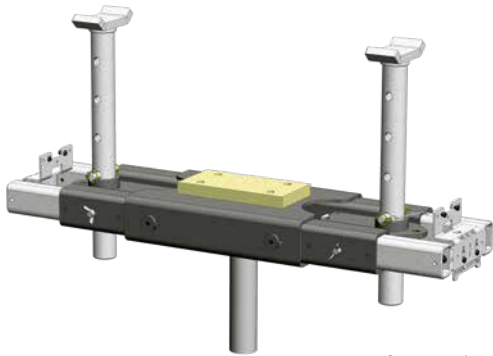

Support in the MIDDLE and in the two-point support area
500 – 900/1,050 mm

Support extenders



Long support tubes (400, 600, 800 mm) can be pushed through from below and thus enable a very high support range within the pit.

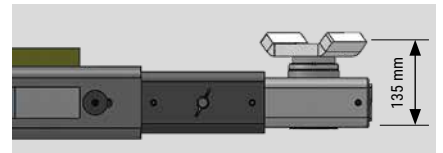

Very flat supports enable trouble-free lifting above the edge of the pit.

Safe vehicle set-down by means of SAT

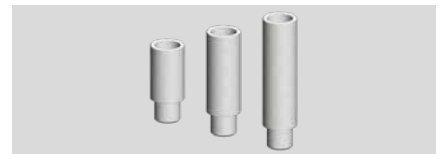
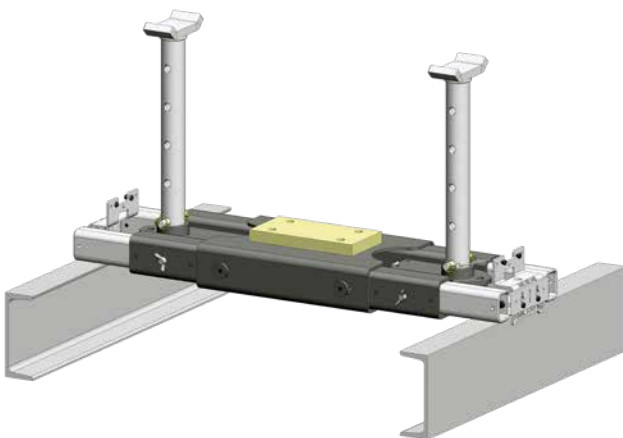

Option: extenders for very flat supports (100, 150, 200 mm).

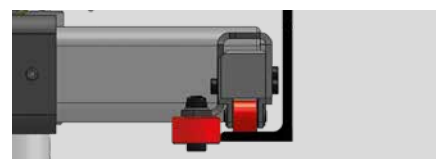

The roller running attachment is recommended for floor-running pit jacks.

Variable SAT set-down

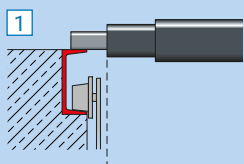

Variant with suspended pit jacks in the U-profile

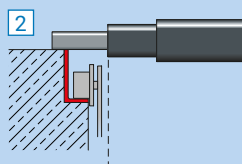

Variant with suspended pit jacks in the L-profile

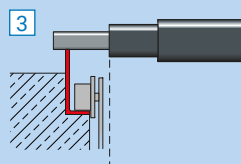

Setting down on the wheel deflector

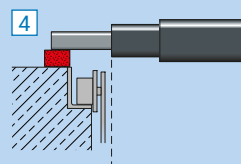

Variant with wooden block additional elevation

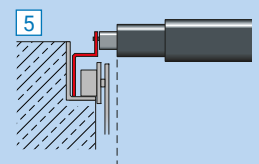

Parking in the pit with set-down plate

GEARBOX MOUNTING TOOL

GMT 800

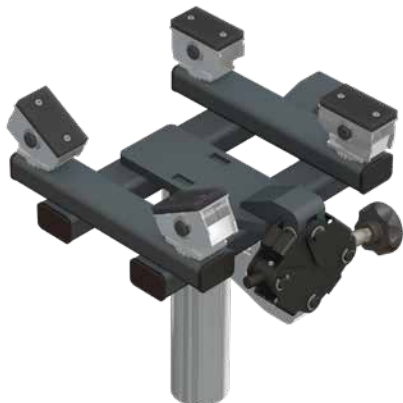

Gearbox mounting tool with movable supports that adapts to the contour of a gearbox, for example. Easily accessible lugs for the tensioning straps (3 m) with quick lashing (x 2) are included.

The tilt is adjusted by means of the hand-turn handle or optionally using a ratchet screwdriver for a greater adjustment path.

The specifically developed scissor spindle adjustment allows movement even when loaded.

Tilt adjustment:

A scissor spindle adjustment with stabilisation and clamping protection is used for smooth and easy-to-operate adjustment of the gearbox tool tilt. The two axes of the GMT 800 can be tilted by $\pm 10^\circ$ or $\pm 15^\circ$.



Planned supports

for GMT 800 with rubber pad (standard scope of delivery)



Semicircular flex mounts

for GMT 800, with rubber pad. Recommended in conjunction with swivel support.



Angle clamp supports

for GMT 800, with rubber pad. Recommended in conjunction with swivel support.

AXLE TRAVERSES WITH SEPARATE SET-DOWN SYSTEM

Axle traverses are needed to lift the vehicles at the designated support points.

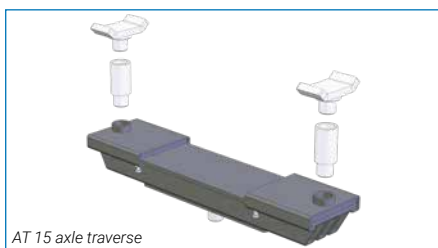

AT 15 axle traverse

AT 15 axle traverse up to a support width of 1,010 mm.

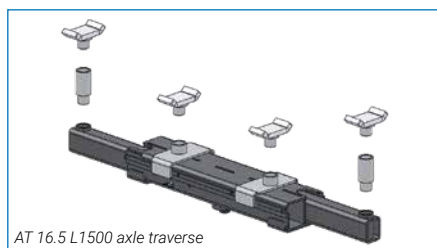

AT 16.5 L1500 axle traverse

AT 16.5 L1500 axle traverse up to a support width of 1,500 mm.

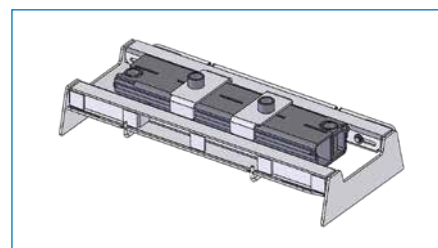

The support bridge for axle traverses can be used to set down a vehicle according to DIN EN 1494, but also to park the axle traverse in the working pit.